

Doro Aurora A20/A21

Repair Manual DSC-0540

English



Contents

1. Repair disclaimer	4
2. About this document	5
2.1 Scope	5
2.2 Who can use this document	5
2.3 How the guide is structured	5
3. General precautions	6
3.1 Use caution before you start to repair	6
3.2 Batteries	6
3.3 Glass handling	7
3.4 Tools and fixtures	7
4. Tools and materials required	8
4.1 Tools	8
4.2 Materials	8
5. Spare parts	9
6. Exploded view	10
7. Block diagram	13
8. Parts location	14
8.1 PCBA ASSY	14
8.2 SIM PCB	16
8.3 USB PCB	17
8.4 ANT PCB (Set 1)	18
8.5 ANT PCB (Set 2)	19
9. How to turn on and off the Doro Aurora A20/A21	20
9.1 Turn on the Aurora A20/A21	20
9.2 Turn the screen on and off	20
9.3 Turn off the Aurora A20/A21	20
10. Repair instructions	21
10.1 How to replace the Battery	21
10.2 How to replace the Display (LCD)	26
11. Disassembly	28
11.1 Disassemble the SIM card tray	28
11.2 Disassemble the Battery cover ASSY	30
11.3 Disassemble the Rear housing ASSY	34
11.4 Disassemble the PCBA ASSY	37
11.5 Disassemble the SIM PCB	40
11.6 Disassemble the USB PCB	42

11.7 Disassemble the USB Light sensor FPC.....	45
11.8 Disassemble the Speaker bracket ASSY.....	47
11.9 Disassemble the ANT PCB.....	49
11.10 Disassemble the Battery.....	51
11.11 Disassemble the Front housing ASSY.....	54
11.12 Disassemble the Flip cover rubber and the Flip decorative part.....	58
11.13 Disassemble the Flip top ASSY.....	61
11.14 Disassemble the Key PCB ASSY.....	64
11.15 Disassemble the Hinge Flip bottom ASSY.....	68
11.16 Disassemble the Hinge FPC.....	72
12. Assembly.....	74
12.1 Assemble the Front housing ASSY.....	74
12.2 Assemble the USB Light sensor FPC.....	77
12.3 Assemble the USB PCB.....	79
12.4 Assemble the SIM PCB.....	81
12.5 Assemble the PCBA ASSY.....	83
12.6 Assemble the ANT PCB.....	86
12.7 Assemble the Hinge FPC.....	90
12.8 Assemble the Hinge Flip bottom ASSY.....	93
12.9 Assemble the Key PCB ASSY.....	97
12.10 Assemble the Flip top ASSY.....	102
12.11 Assemble the Flip cover rubber and the Flip decorative part.....	105
12.12 Assemble the Battery.....	108
12.13 Assemble the Rear housing ASSY.....	111
12.14 Assemble the Speaker bracket ASSY.....	113
12.15 Assemble the Battery cover ASSY.....	115
12.16 Assemble the SIM card tray.....	118
13. Troubleshooting.....	119
13.1 Reset software.....	119
13.2 Device boot options.....	119
14. Appendix.....	120

1. Repair disclaimer

Self-service repair is not recommended unless you have the necessary technical knowledge and experience to safely handle electronic components. Attempting repairs without proper expertise can result in damage to the device, personal injury, or voiding of any applicable warranty.

By choosing to proceed with a self-repair, you acknowledge and accept all risks and responsibilities associated with the process.

2. About this document

This document provides step-by-step instructions for repairing and maintaining the Aurora A20/A21. It is designed to support both professional technicians and private individuals who wish to perform their own repairs.

2.1 Scope

This guide covers:

- Safe disassembly and reassembly procedures
- Replacement of specific hardware components
- Basic troubleshooting and visual inspections

This guide does not cover:

- Advanced electrical diagnostics
- Software-level repairs or firmware issues
- Modifications outside manufacturer specifications

2.2 Who can use this document

This guide is intended for:

- Technicians and repair professionals
- End customers interested in do-it-yourself repairs, as encouraged by the EcoDesign directive

2.3 How the guide is structured

The document is divided into the following main sections:

- Safety Information
- Required tools and materials
- Component-specific replacements
- Disassembly Procedures
- Assembly Instructions
- Troubleshooting

Each chapter includes checklists, simple step-by-step instructions, and references to related sections within this document.

3. General precautions

Before you service the product, read the full set of precautions in this document.

3.1 Use caution before you start to repair



CAUTION

Opening or repairing a device could cause electric shock, device damage, fire, personal injury risks, and other hazards.

- Make sure that the work surface is clean and free of debris to prevent contamination of internal components.
- Wear an ESD wrist strap to prevent electrostatic discharge damage to sensitive electronic components.
- Always perform repairs in a clean, dry space with good ventilation and no combustible materials.
- Make sure no cables or components are damaged during removal. Damaged cables and components must be replaced.
- Ensure that there are no additional screws or small parts left in the device after assembly.
- Always ensure that screws are securely fastened.
- Disconnect the device from all power sources before any disassembly.

3.2 Batteries

Batteries should be handled with care, and could be dangerous if not in normal condition.

 CAUTION

- Discharge the battery before you attempt repair.
- Never bend, dent, puncture, or use tools to pry the battery.
- To prevent damage, store replaced batteries in the replacement packaging directly after being replaced.
- If the battery shows signs of swelling or damage, or if the device feels hot or emits a strong odour, don't attempt disassembly. Please reach out to Doro support.
- If a battery starts to vent, cover it in sand or use gloves and pliers to dispose the battery in a fire safe container as soon as possible.
- Be careful with the following unacceptable battery conditions: pouch damage, line protrusion, scratch, contamination mark, dot protrusion, dent, bubbling, imprinted line, swelling or electrolyte leakage.
- Do not shortcut the battery terminals or damage the battery, as it could result in fire or overheating.
- Do not throw the old battery in regular trash. Dispose of the battery according to local regulations.

3.3 Glass handling

 CAUTION

- Wear protective gloves and safety glasses when you handle broken glass parts.
- Apply protective film when you remove damaged glass parts.
- Place the damaged glass part in the spare part packaging directly after replacement to prevent injury.

3.4 Tools and fixtures

The use of correct tools and fixtures is strongly recommended for all device repairs.





 CAUTION

- We don't recommend repairs without the correct tools and fixtures.
- Improper use of tools and fixtures may result in injury, damage to the product, tools, fixtures, or spare parts.

4. Tools and materials required

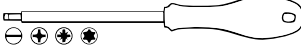
4.1 Tools

The tools listed are basic tools that can be used to do a repair, reuse or upgrade.

Tool type	Illustration (informative example)	Reference
Screwdriver (for slotted heads, cross recess or hexalobular recess heads)		ISO 2380, ISO 8764, ISO 10664
Prying lever		
Tweezers		
Plectrum		
Suction cup with keyring		

4.2 Materials

Material type	Reference
Isopropanol	Commonly available isopropanol (IPA), $\geq 70\%$ concentration

5. Spare parts

This document does not include the complete Spare Parts List. The Spare Parts List covers all components of the product and can be found at:

<https://www.doro.com/repair/>

6. Exploded view

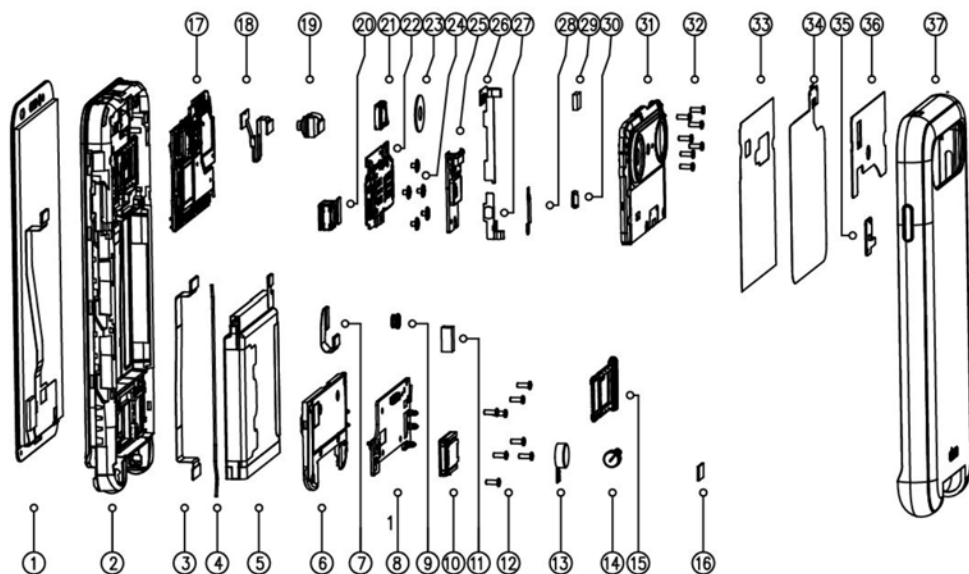

No	Part name	Qty
1	TP+LCD	1
2	Front body comp	1
3	Antenna board FPC	1
4	RF cable	1
5	Battery	1
6	Speaker bracket ASSY	1
7	SIM card FPC connection	1
8	ANT PCB	1
9	Rubber sleeve front camera	1
10	Speaker	1
11	Speaker conductive cloth	
12	Screw2 bracket	
13	Motor	1
14	Sealing silicone A hinge	1
15	SIM card tray	1
16	Black sealing tape	2

No	Part name	Qty
17	PCBA ASSY	1
18	USB Light sensor FPC	1
19	Front camera 5M	1
20	Rear main camera 13M	1
21	Receiver	1
22	SIM PCB	1
23	Camera lens	1
24	Screw1 SIM sub board	5
25	USB PCB	1
26	Volume key FPC	1
27	Power key FPC	1
28	Steel buckle	1
29	Sensor rubber sleeve	1
30	Hinge	1
31	Rear housing ASSY	1
32	Screw3 PCBA	6
33	Graphite sheet	1
34	Wireless charging coil	1
35	Flash PCB	1
36	NFC antenna	1
37	Battery cover ASSY	1

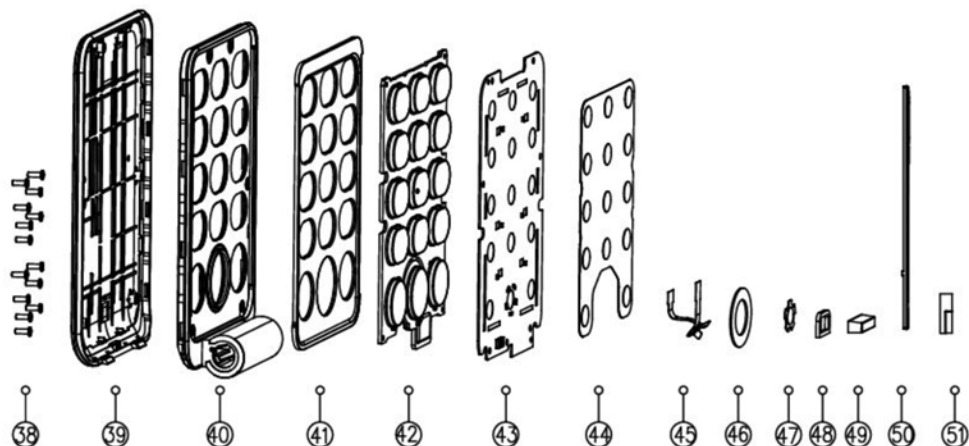

No	Part name	Qty
38	Screw4 flip top bottom cover	13
39	Flip top ASSY	1
40	Flip bottom Assy [B371-0980-B020]	1
41	Flip decorative part	1
42	Keypad	1
43	Key PCB ASSY	1
44	Keypad Dome	1
45	Hinge FPC	1
46	Light guide plate	1
47	Home key dome	1
48	Sealing silicone keypad connector	1
49	Sealing silicone C hinge	1
50	Flip cover rubber	1
51	Sealing silicone B hinge	1

7. Block diagram

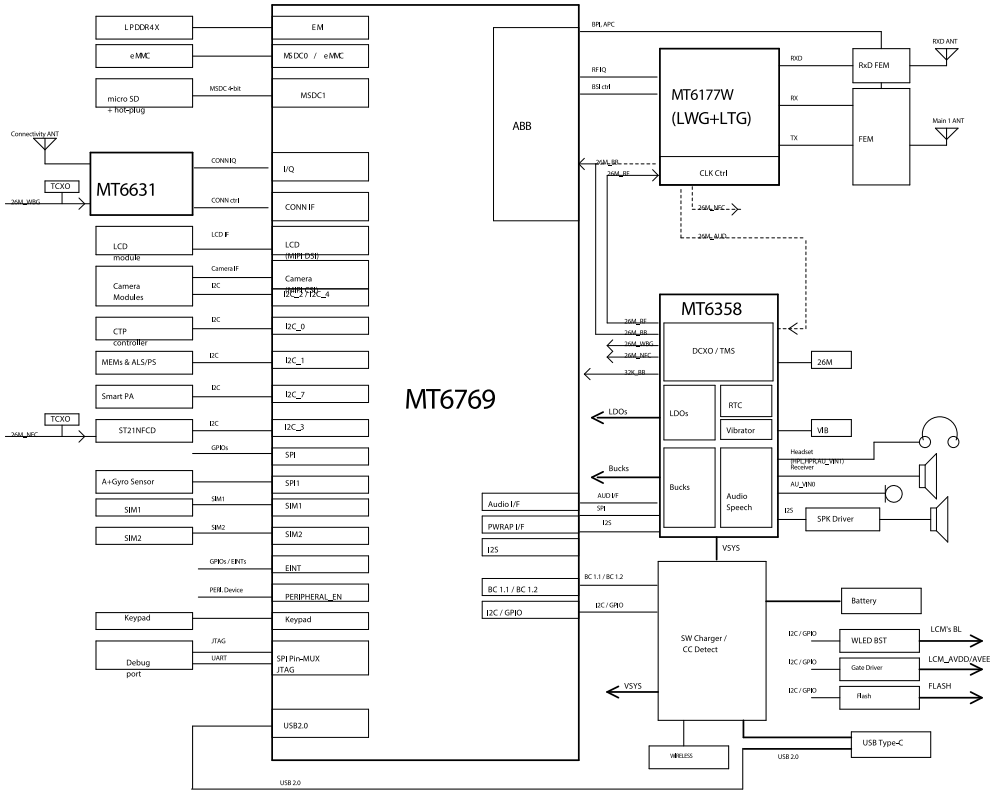

8. Parts location

8.1 PCBA ASSY

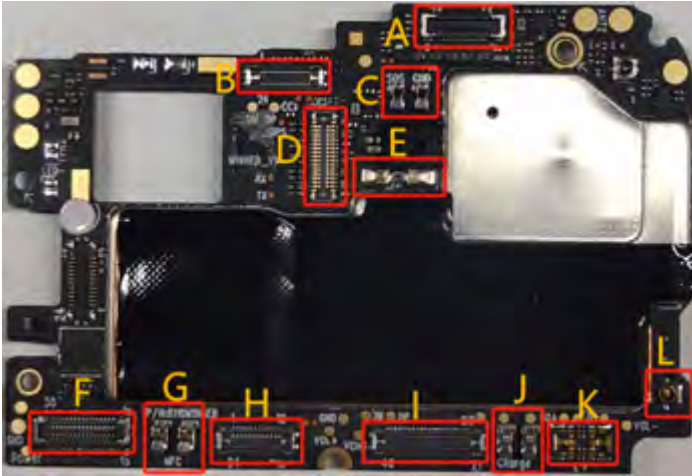

Location	Description
A	Front camera connector
B	USB & Ambient Light Sensor FPC Connector
C	SOS Button pad
D	Rear Main Camera Connector
E	Flashlight Pad

Location	Description
F	LCD Connector
G	NFC Pad
H	SIM Tray FPC Connector
I	Main FPC Connector
J	Earpiece (Receiver) Pad
K	Battery Connector
L	RF Cable Connector
M	Volume Key Pad
N	Power Key Pad

8.2 SIM PCB



Location	Description
A	SIM Tray FPC Connector

8.3 USB PCB

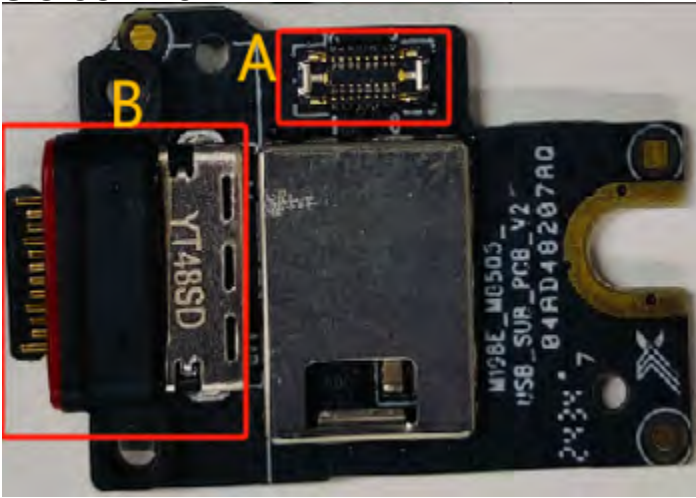

Location	Description
A	USB & Ambient Light Sensor FPC Connector
B	USB Port

8.4 ANT PCB (Set 1)

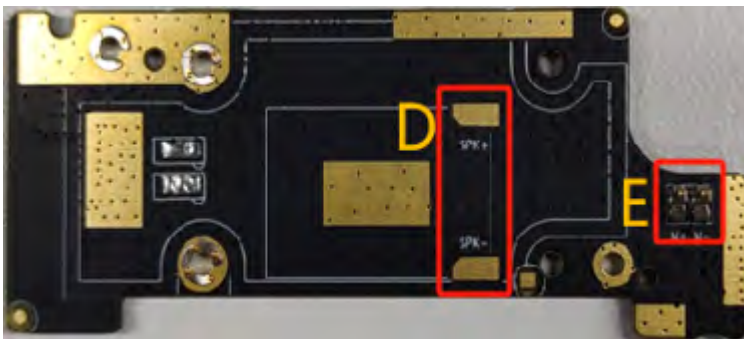

Location	Description
A	Main FPC Connector
B	RF Cable Connector
C	Hinge FPC Connector
D	Speaker Pad
E	Vibration Motor Pad

8.5 ANT PCB (Set 2)



Location	Description
A	Hinge FPC Connector

9. How to turn on and off the Doro Aurora A20/A21

Before performing any repair, the device must be turned off to prevent damage to internal components and to ensure safety during disassembly.

After the repair is completed and the device is fully reassembled, you will need to turn it on again to verify that it is functioning as expected.

9.1 Turn on the Aurora A20/A21

1. Press and hold the power button until the display lights up.

9.2 Turn the screen on and off

1. When the phone is on, press the power button once to turn the screen on or off.

9.3 Turn off the Aurora A20/A21

1. Press and hold the Power button until the options menu opens.
2. In the options menu, tap Power off (optionally, press Restart to restart or Lockdown).

For the full manual with all functions and features, see *Appendix*, p.120.

10. Repair instructions

10.1 How to replace the Battery

10.1.1 Purpose

This procedure explains how to replace the **Battery** of the device.

10.1.2 Prerequisites

The following disassembly sections needs to be done before continuing.

- *Disassemble the SIM card tray*, p.28
- *Disassemble the Battery cover ASSY*, p.30
- *Disassemble the Rear housing ASSY*, p.34

10.1.3 Tools and equipment

Type	Reference
Screwdriver	ISO 2380, ISO 8764, ISO 10664

10.1.4 Spare parts

Qty	Spare part	Information
1	Battery	

10.1.5 Safety and precautions

See *General precautions*, p.6.

10.1.6 Procedure overview

The **Battery** is enclosed in multiple layers of protective film. Start by removing the visible top layer of protective film. When removing the **Battery**, use the tab of protective film located underneath the battery to help lift it out.

10.1.7 Step-by-step instructions

1. Disconnect the battery connector.



2. Locate the center plastic strip on the protective film. This is the tab used for **Battery** removal.



3. Firmly pull the remaining plastic strip to lift the **Battery** out of the battery compartment.



4. Lift off the **Battery** that needs to be replaced.



5. Position the replacement **Battery** in the battery compartment of the device.



6. Connect the **Battery** to the designated connector (marked red) on the .



7. Position the on the device and align the screw holes on both parts.

**Note!**

Push the **Rear housing ASSY** into the correct position until it snaps into place.

8. Fasten the Rear housing ASSY with the Screw2 bracket**10.1.8 After-removal checks**

- Check that the components are not damaged. Any damaged components should be replaced.

10.1.9 Reassembly reference

To complete the full assembly of the device, the following sections must be completed:

- *Assemble the Battery cover ASSY, p.115*

- *Assemble the SIM card tray*, p.118

10.1.10 Troubleshooting and tips

10.2 How to replace the Display (LCD)

10.2.1 Purpose

This procedure explains how to replace the **Display (LCD)** of the device.

10.2.2 Prerequisites

The following disassembly sections needs to be done before continuing.

- *Disassemble the SIM card tray*, p.28
- *Disassemble the Battery cover ASSY*, p.30
- *Disassemble the Rear housing ASSY*, p.34
- *Disassemble the PCBA ASSY*, p.37
- *Disassemble the SIM PCB*, p.40
- *Disassemble the USB PCB*, p.42
- *Disassemble the USB Light sensor FPC*, p.45
- *Disassemble the Speaker bracket ASSY*, p.47
- *Disassemble the ANT PCB*, p.49
- *Disassemble the Battery*, p.51
- *Disassemble the Front housing ASSY*, p.54
- *Disassemble the Flip cover rubber and the Flip decorative part*, p.58
- *Disassemble the Flip top ASSY*, p.61
- *Disassemble the Key PCB ASSY*, p.64
- *Disassemble the Hinge Flip bottom ASSY*, p.68
- *Disassemble the Hinge FPC*, p.72

10.2.3 Tools and equipment

No tools are required for this procedure. Tools used in earlier procedures are listed in their respective chapters.

10.2.4 Spare parts

Qty	Spare part	Information
1	Front housing ASSY	

10.2.5 Safety and precautions

See *General precautions*, p.6.

10.2.6 Procedure overview

The **Display (LCD)** is attached to the **Front housing ASSY**. To replace the **Display (LCD)**, the **Front housing ASSY** needs to be replaced.

10.2.7 Step-by-step instructions

Replace the old **Front housing ASSY** (including **Display (LCD)**) with the new **Front housing ASSY**.

10.2.8 After-removal checks

- Check that the components are not damaged. Any damaged components should be replaced.

10.2.9 Reassembly reference

To complete the full assembly of the device, the following sections must be completed:

- *Assemble the Hinge FPC*, p.90
- *Assemble the Hinge Flip bottom ASSY*, p.93
- *Assemble the Key PCB ASSY*, p.97
- *Assemble the Flip top ASSY*, p.102
- *Assemble the Flip cover rubber and the Flip decorative part*, p.105
- *Assemble the Front housing ASSY*, p.74
- *Assemble the ANT PCB*, p.86
- *Assemble the Speaker bracket ASSY*, p.113
- *Assemble the USB Light sensor FPC*, p.77
- *Assemble the USB PCB*, p.79
- *Assemble the SIM PCB*, p.81
- *Assemble the PCBA ASSY*, p.83
- *Assemble the Rear housing ASSY*, p.111
- *Assemble the Battery cover ASSY*, p.115
- *Assemble the SIM card tray*, p.118
- *Assemble the Battery*, p.108

10.2.10 Troubleshooting and tips

11. Disassembly

11.1 Disassemble the SIM card tray

11.1.1 Purpose

Removing the SIM card tray is typically the first step in every repair on a smartphone.

11.1.2 Tools and equipment

No tools are required for this procedure. Tools used in earlier procedures are listed in their respective chapters.

11.1.3 Spare parts

Qty	Spare part	Information
1	SIM card tray	

11.1.4 Safety and precautions

See *General precautions*, p.6.

11.1.5 Pre-removal checklist

- Turn off the phone, see *How to turn on and off the Doro Aurora A20/A21*, p.20.
- Disconnect from charger or any peripherals.

11.1.6 Procedure overview

Use your finger or a similar tool to carefully pull out the .

11.1.7 Step-by-step instructions

1. Locate the groove of the **SIM card tray**.
2. Carefully pull out the **SIM card tray** using your finger or a suitable non-metallic tool.



CAUTION

Do not insert a needle or other sharp object into any hole on the device. The **SIM card tray** is designed to be removed by pulling only, no special tool is required.

11.1.8 After-removal checks

- Place the SIM card and any memory card in a safe location to avoid loss or damage.
- Check that the tray is not bent or cracked, and that no debris remains in the SIM slot.

11.1.9 Troubleshooting tips

—

11.1.10 Related information

- *Assemble the SIM card tray*, p.118

11.2 Disassemble the Battery cover ASSY

11.2.1 Purpose

Most components like the battery, motherboard, camera, buttons, charging port, etc. are housed beneath the **Battery cover ASSY**. You need to remove it to get to these.

11.2.2 Tools and equipment

Type	Reference
Plectrum	

11.2.3 Spare parts

Qty	Spare part	Information
1	Battery cover ASSY	
1	Sealing foam battery cover	
1	Sealing foam adhesive	

11.2.4 Safety and precautions

See *General precautions*, p.6.

11.2.5 Pre-removal checklist

Before proceeding with this disassembly, please make sure you have read and completed the following chapters:

- *Disassemble the SIM card tray*, p.28

11.2.6 Procedure overview

The **Battery cover ASSY** is loosened by inserting a **Plectrum** between the **Battery cover ASSY** and the device and carefully sliding it along the edges.

11.2.7 Step-by-step instructions

1. Insert the **Plectrum** approximately 2 mm into the gap between the **Battery cover ASSY** and the display.



CAUTION

Inserting the **Plectrum/Prying lever** more than 2 mm may damage internal components.

- Slide the **Plectrum** along the sides and the top edge until the **Battery cover ASSY** opens.

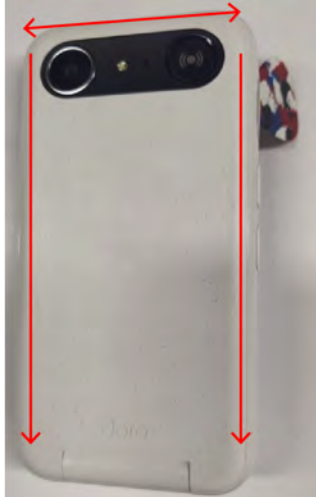

- Once the top and side edges are loosened, firmly push the **Battery cover ASSY** toward the bottom of the device.

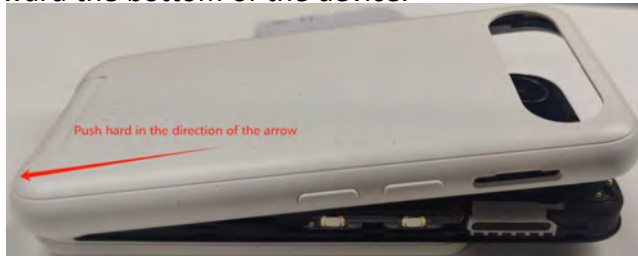

- Once fully loosened, carefully lift off the **Battery cover ASSY**.

11.2.8 After-removal checks

- Make sure no cables or components are damaged during removal. Damaged cables and components must be replaced.
- Inspect the **Sealing foam battery cover** (marked in the red box) and the (marked in the green box).
If either is damaged, clean the affected area and replace the material as needed.



- Check that the tray is not bent or cracked, and that no debris remains in the SIM slot.
- Check that no dust and debris remains in the **Rear housing ASSY**.

**Note!**

The **Sealing foam battery cover** at the bottom of the **Battery cover ASSY** is particularly easy to damage if the **Plectrum** is inserted too far during disassembly. Inspect this area closely and make sure no tearing or deformation has occurred.

11.2.9 Troubleshooting tips

- When removing the **Battery cover ASSY**, use the correct technique to avoid damage. Do not force the cover open, as it has a curved design that can crack or deform under pressure. Follow the step-by-step instructions carefully to remove the cover safely.

11.2.10 Related information

- *Assemble the Battery cover ASSY*, p.115

11.3 Disassemble the Rear housing ASSY

11.3.1 Purpose

Most components like the battery, motherboard, camera, buttons, charging port, etc. are housed beneath the **Rear housing ASSY**. You need to remove it to get to these.

11.3.2 Tools and equipment

Type	Reference
Screwdriver	ISO 2380, ISO 8764, ISO 10664
Prying lever	

11.3.3 Spare parts

Qty	Spare part	Information
1	Rear housing ASSY	
1	Black sealing tape	
7	Screw2 bracket	
1	LED light board foam	
1	Flash PCB	

11.3.4 Safety and precautions

See *General precautions*, p.6.

11.3.5 Pre-removal checklist

Before proceeding with this disassembly, please make sure you have read and completed the following chapters:

- *Disassemble the SIM card tray*, p.28
- *Disassemble the Battery cover ASSY*, p.30

11.3.6 Procedure overview

The **Rear housing ASSY** is loosened by removing the **Screw2 bracket**.

11.3.7 Step-by-step instructions

1. Remove the **Screw2 bracket** marked red.



2. Use a **Prying lever** or a **Plectrum** to pry off the **Rear housing ASSY**.

Note!

When using a **Prying lever** or a **Plectrum**, be careful not to damage the components housed under the **Rear housing ASSY**.



11.3.8 After-removal checks

- Make sure no cables or components are damaged during removal. Damaged cables and components must be replaced.

11.3.9 Troubleshooting tips

- When removing the **Rear housing ASSY**, use the correct technique to avoid damage. Do not force the cover open, as it has a curved design that can crack or deform under pressure. Follow the step-by-step instructions carefully to remove the cover safely.

11.3.10 Related information

- *Assemble the Rear housing ASSY*, p.111

11.4 Disassemble the PCBA ASSY

11.4.1 Purpose

Removing the **PCBA ASSY** provides access to the components located behind it, including the **SIM PCB**, the **USB PCB**, and various sensors.

11.4.2 Tools and equipment

Type	Reference
Screwdriver	ISO 2380, ISO 8764, ISO 10664

11.4.3 Spare parts

Qty	Spare part	Information
1	PCBA ASSY	
1	Front camera 5M	
1	Rear main camera 13M	
1	Rubber sleeve front camera	
2	Screw3 PCBA	

11.4.4 Safety and precautions

See *General precautions*, p.6.

11.4.5 Pre-removal checklist

Before proceeding with this disassembly, please make sure you have read and completed the following chapters:

- *Disassemble the SIM card tray*, p.28
- *Disassemble the Battery cover ASSY*, p.30
- *Disassemble the Rear housing ASSY*, p.34

11.4.6 Procedure overview

The **PCBA ASSY** is loosened by removing the **Screw3 PCBA**.

11.4.7 Step-by-step instructions

1. Disconnect all connectors in numeric order according to the image. It is important to start with number 1, the battery connector, for safety reasons. Disconnect the , number 6, last. This cable is extra fragile, so take care when removing it.

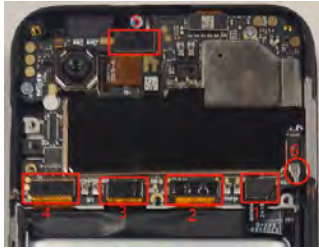

2. Remove the **Screw3 PCBA**.



3. Lift off the **PCBA ASSY**.

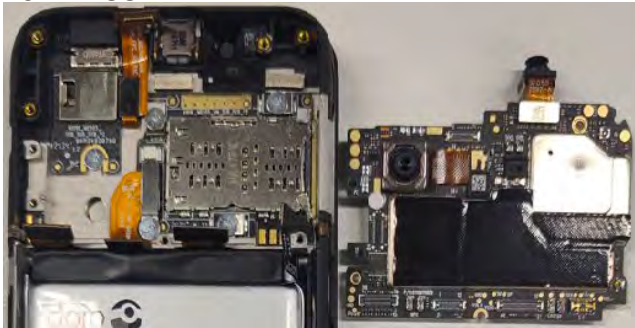

4. Locate and remove the **Front camera 5M** and the **Rear main camera 13M**.



11.4.8 After-removal checks

- Make sure no cables or components are damaged during removal. Damaged cables and components must be replaced.

11.4.9 Troubleshooting tips

—

11.4.10 Related information

- *Assemble the PCBA ASSY*, p.83

11.5 Disassemble the SIM PCB

11.5.1 Purpose

Disassembling the **SIM PCB** is done to replace malfunctioning components or to access and repair connections related to the SIM card functionality. This procedure may be necessary if there are issues with the SIM card reader, connections, or other internal components of the **SIM PCB**.

11.5.2 Tools and equipment

Type	Reference
Screwdriver	ISO 2380, ISO 8764, ISO 10664

11.5.3 Spare parts

Qty	Spare part	Information
1	SIM PCB	
4	Screw1 SIM sub board	
1	Steel buckle	
1	SIM card FPC connection	

11.5.4 Safety and precautions

See *General precautions*, p.6.

11.5.5 Pre-removal checklist

Before proceeding with this disassembly, please make sure you have read and completed the following chapters:

- *Disassemble the SIM card tray*, p.28
- *Disassemble the Battery cover ASSY*, p.30
- *Disassemble the Rear housing ASSY*, p.34
- *Disassemble the PCBA ASSY*, p.37

11.5.6 Procedure overview

This procedure outlines the steps to remove the **SIM PCB**, including disconnecting the **SIM card FPC connection**.

11.5.7 Step-by-step instructions

1. Remove the **Screw1 SIM sub board**.

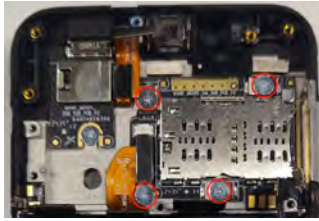

2. Remove the **Steel buckle**.

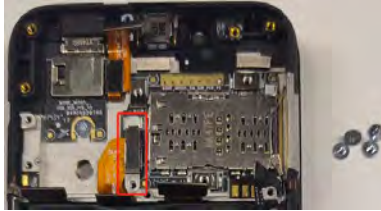

3. Lift off the **SIM PCB**.

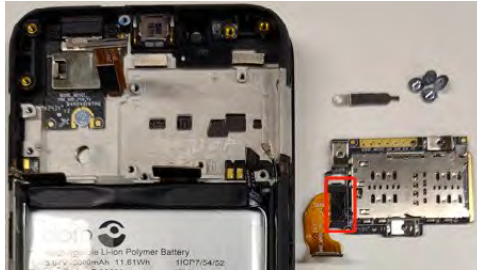

11.5.8 After-removal checks

- Check that the **SIM PCB** is not bent or damaged. A damaged **SIM PCB** must be replaced.

11.5.9 Troubleshooting tips

—

11.5.10 Related information

- *Assemble the SIM PCB*, p.81

11.6 Disassemble the USB PCB

11.6.1 Purpose

Removing the **USB PCB** grants access to the components located behind it and enables replacement of the **USB PCB** itself.

11.6.2 Tools and equipment

Type	Reference
Screwdriver	ISO 2380, ISO 8764, ISO 10664
Tweezers	

11.6.3 Spare parts

Qty	Spare part	Information
1	USB PCB	
1	Screw1 SIM sub board	
2	Screw2 bracket	

11.6.4 Safety and precautions

See *General precautions*, p.6.

11.6.5 Pre-removal checklist

Before proceeding with this disassembly, please make sure you have read and completed the following chapters:

- *Disassemble the SIM card tray*, p.28
- *Disassemble the Battery cover ASSY*, p.30
- *Disassemble the Rear housing ASSY*, p.34
- *Disassemble the PCBA ASSY*, p.37

11.6.6 Procedure overview

The **USB PCB** is loosened by removing the **Screw1 SIM sub board** and the **Screw2 bracket**.

11.6.7 Step-by-step instructions

1. Remove the **Screw1 SIM sub board** and the **Screw2 bracket**.



2. Use Tweezers to carefully pry up one end of the **USB PCB**.

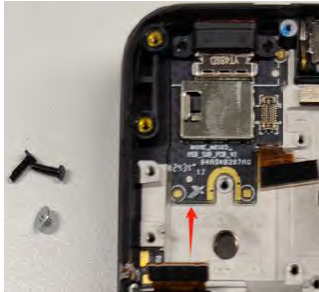

3. Carefully wiggle and pull the **USB PCB** to remove it.



Note!

If any tools (e.g. **Tweezers**) are used to remove the **USB PCB**, take care not to damage it.

Note!

Do not damage the silicone of the USB connector.

11.6.8 After-removal checks

- If there is any damage to the silicone, the **USB PCB** must be replaced.

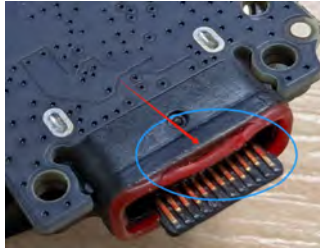

11.6.9 Troubleshooting tips

—

11.6.10 Related information

- *Assemble the USB PCB*, p.79

11.7 Disassemble the USB Light sensor FPC

11.7.1 Purpose

Removing the **USB Light sensor FPC** grants access to the components located behind it and enables replacement of the **USB Light sensor FPC** itself.

11.7.2 Tools and equipment

Type	Reference
Prying lever	
Tweezers	

11.7.3 Spare parts

Qty	Spare part	Information
1	USB Light sensor FPC	
1	Sensor rubber sleeve	

11.7.4 Safety and precautions

See *General precautions*, p.6.

11.7.5 Pre-removal checklist

Before proceeding with this disassembly, please make sure you have read and completed the following chapters:

- *Disassemble the SIM card tray*, p.28
- *Disassemble the Battery cover ASSY*, p.30
- *Disassemble the Rear housing ASSY*, p.34
- *Disassemble the PCBA ASSY*, p.37
- *Disassemble the USB PCB*, p.42

11.7.6 Procedure overview

The **USB Light sensor FPC** is disassembled using a **Prying lever**.

11.7.7 Step-by-step instructions

1. Lightly pry up the **USB Light sensor FPC** with a **Prying lever**.



2. Lift off the **USB Light sensor FPC**.

11.7.8 After-removal checks

- Inspect the **USB Light sensor FPC** for any signs of tearing or damage.

11.7.9 Troubleshooting tips

—

11.7.10 Related information

- *Assemble the USB Light sensor FPC, p.77*

11.8 Disassemble the Speaker bracket ASSY

11.8.1 Purpose

The **Speaker bracket ASSY** is disassembled if it needs to be replaced or to access the components behind it.

11.8.2 Tools and equipment

Type	Reference
Screwdriver	ISO 2380, ISO 8764, ISO 10664
Tweezers	

11.8.3 Spare parts

Qty	Spare part	Information
1	Speaker bracket ASSY	
9	Screw2 bracket	

11.8.4 Safety and precautions

See *General precautions*, p.6.

11.8.5 Pre-removal checklist

Before proceeding with this disassembly, please make sure you have read and completed the following chapters:

- *Disassemble the SIM card tray*, p.28
- *Disassemble the Battery cover ASSY*, p.30
- *Disassemble the Rear housing ASSY*, p.34

11.8.6 Procedure overview

The **Speaker bracket ASSY** is disassembled by removing the **Screw2 bracket**.

11.8.7 Step-by-step instructions

1. Remove the **Screw2 bracket** on the **Speaker bracket ASSY**.



2. Lift off the **Speaker bracket ASSY** from the device.



11.8.8 After-removal checks

- Inspect the **Speaker** and, in particular, the speaker pins for bending or damage.

11.8.9 Troubleshooting tips

—

11.8.10 Related information

- *Assemble the Speaker bracket ASSY*, p.113

11.9 Disassemble the ANT PCB

11.9.1 Purpose

This procedure covers the steps to disconnect the antenna components.

11.9.2 Tools and equipment

Type	Reference
Screwdriver	ISO 2380, ISO 8764, ISO 10664

11.9.3 Spare parts

Qty	Spare part	Information
1	ANT PCB	
8	Screw3 PCBA	
1	RF cable	
1	Speaker conductive cloth	

11.9.4 Safety and precautions

See *General precautions*, p.6.

11.9.5 Pre-removal checklist

Before proceeding with this disassembly, please make sure you have read and completed the following chapters:

- *Disassemble the SIM card tray*, p.28
- *Disassemble the Battery cover ASSY*, p.30
- *Disassemble the Rear housing ASSY*, p.34
- *Disassemble the Speaker bracket ASSY*, p.47

11.9.6 Procedure overview

Disconnect the **FPC** and cables first. The **ANT PCB** is disassembled by removing the **Screw3 PCBA**.

11.9.7 Step-by-step instructions

1. Disconnect the connectors and the remove the **Screw3 PCBA**.



2. Lift off the **ANT PCB** and fully disconnect the **RF cable**.



11.9.8 After-removal checks

- Inspect the **ANT PCB** for bending or damage.
- Make sure no cables or components are damaged during removal. Damaged cables and components must be replaced.

11.9.9 Troubleshooting tips

—

11.9.10 Related information

- *Assemble the ANT PCB*, p.86

11.10 Disassemble the Battery

11.10.1 Purpose

This procedure explains how to remove the **Battery** to get access to the parts behind it.

To change the battery, please refer to *How to replace the Battery*, p.21 instead.

11.10.2 Tools and equipment

Type	Reference
Prying lever	

11.10.3 Spare parts

Qty	Spare part	Information
1	Battery	
1	Battery adhesive A	
1	Battery adhesive B	
1	Battery adhesive C	

11.10.4 Safety and precautions

See *General precautions*, p.6.

11.10.5 Pre-removal checklist

Before proceeding with this disassembly, please make sure you have read and completed the following chapters:

- *Disassemble the SIM card tray*, p.28
- *Disassemble the Battery cover ASSY*, p.30
- *Disassemble the Rear housing ASSY*, p.34

11.10.6 Procedure overview

The **Battery** is enclosed in multiple layers of protective film. When removing the battery, use the tab of protective film located underneath the battery to help lift it out.

11.10.7 Step-by-step instructions

1. Locate the center plastic strip on the protective film. This is the tab used for **Battery** removal.



2. Firmly pull the remaining plastic strip to lift the **Battery** out of the battery compartment.



3. Lift off the **Battery**.



11.10.8 After-removal checks

- Check that the battery is not punctured, crushed, or bent. A damaged battery can leak, catch fire, or even explode.

11.10.9 Troubleshooting tips

—

11.10.10 Related information

- *Assemble the Battery*, p.108

11.11 Disassemble the Front housing ASSY

11.11.1 Purpose

These steps describe how to disassemble the **Front housing ASSY** into individual components. While this procedure may not be necessary for all repairs, it is essential when needing to access parts like the receiver or buttons, which can be replaced independently.

11.11.2 Tools and equipment

Type	Reference
Prying lever	

11.11.3 Spare parts

Qty	Spare part	Information
1	Front housing ASSY	
1	Receiver	
1	Power key FPC	
1	Motor	
1	Antenna board FPC	
1	Volume key FPC	

11.11.4 Safety and precautions

See *General precautions*, p.6.

11.11.5 Pre-removal checklist

Before proceeding with this disassembly, please make sure you have read and completed the following chapters:

- *Disassemble the SIM card tray*, p.28
- *Disassemble the Battery cover ASSY*, p.30
- *Disassemble the Rear housing ASSY*, p.34
- *Disassemble the PCBA ASSY*, p.37
- *Disassemble the SIM PCB*, p.40
- *Disassemble the USB PCB*, p.42
- *Disassemble the USB Light sensor FPC*, p.45
- *Disassemble the Speaker bracket ASSY*, p.47

- *Disassemble the ANT PCB, p.49*
- *Disassemble the Battery, p.51*

11.11.6 Procedure overview

There are several parts that can be disassembled from the **Front housing ASSY** and they can be removed separately in no particular order.

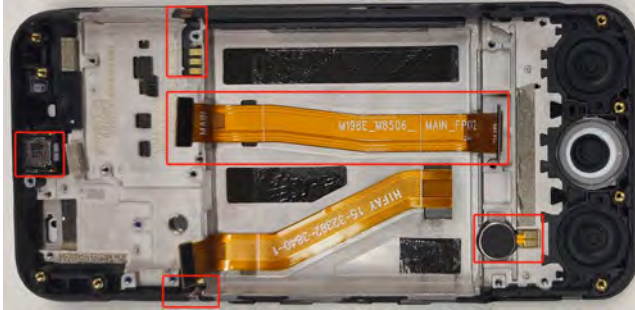

11.11.7 Step-by-step instructions

1. Use a prying lever in the designated groove in the **Front housing ASSY** to carefully pry the **Receiver** upward.



2. Use a **Prying lever** to pry up the **Power key FPC**.



3. Use a **Prying lever** to pry up the **Volume key FPC**.



4. Use a **Prying lever** to pry up the **Motor**.



5. Remove the **Sealing silicone C hinge** using **Tweezers**.



6. Disconnect and remove the **Antenna board FPC**.



11.11.8 After-removal checks

- Make sure no cables or components are damaged during removal. Damaged cables and components must be replaced.
- Inspect the adhesive tape to determine if it can be reused. It should retain enough adhesion to secure the battery.

11.11.9 Troubleshooting tips

—

11.11.10 Related information

- *Assemble the Front housing ASSY, p.74*

11.12 Disassemble the Flip cover rubber and the Flip decorative part

11.12.1 Purpose

These steps describe how to disassemble the **Flip cover rubber** and the **Flip decorative part**.

11.12.2 Tools and equipment

Type	Reference
Prying lever	
Plectrum	

11.12.3 Spare parts

11.12.4 Safety and precautions

See *General precautions*, p.6.

11.12.5 Pre-removal checklist

Before proceeding with this disassembly, please make sure you have read and completed the following chapters:

- Turn off the phone, see *How to turn on and off the Doro Aurora A20/A21*, p.20.
- Disconnect from charger or any peripherals.

11.12.6 Procedure overview

The **Flip cover rubber** and the **Flip decorative part** are removed with the **Prying lever** and the **Plectrum**.

11.12.7 Step-by-step instructions

1. Use a **Prying lever** to remove the **Flip cover rubber**.



2. Insert the **Plectrum** between the **Hinge Flip bottom ASSY** and the **Flip decorative part** to pry up the **Flip decorative part**.



3. Lift off the **Flip decorative part**.



11.12.8 After-removal checks

- Make sure no cables or components are damaged during removal. Damaged cables and components must be replaced.

11.12.9 Troubleshooting tips

—

11.12.10 Related information

- *Assemble the Flip cover rubber and the Flip decorative part, p.105*

11.13 Disassemble the Flip top ASSY

11.13.1 Purpose

These steps describe how to disassemble the **Flip cover rubber** and the **Flip decorative part**.

11.13.2 Tools and equipment

Type	Reference
Prying lever	
Plectrum	

11.13.3 Spare parts

11.13.4 Safety and precautions

See *General precautions*, p.6.

11.13.5 Pre-removal checklist

Before proceeding with this disassembly, please make sure you have read and completed the following chapters:

- *Disassemble the Flip cover rubber and the Flip decorative part*, p.58

11.13.6 Procedure overview

The **Flip cover rubber** and the **Flip decorative part** are removed with the **Prying lever** and the **Plectrum**.

11.13.7 Step-by-step instructions

1. Use a **Prying lever** to remove the **Flip cover rubber**.



2. Insert the **Plectrum** between the **Hinge Flip bottom ASSY** and the **Flip decorative part** to pry up the **Flip decorative part**.



3. Lift off the **Flip top ASSY**.



11.13.8 After-removal checks

- Make sure no cables or components are damaged during removal. Damaged cables and components must be replaced.

11.13.9 Troubleshooting tips

—

11.13.10 Related information

- *Assemble the Flip top ASSY, p.102*

11.14 Disassemble the Key PCB ASSY

11.14.1 Purpose

These steps describe how to disassemble the **Key PCB ASSY**.

11.14.2 Tools and equipment

Type	Reference
Screwdriver	ISO 2380, ISO 8764, ISO 10664
Tweezers	

11.14.3 Spare parts

Qty	Spare part	Information
1	Key PCB ASSY	
1	Sealing silicone B hinge	
7	Screw4 flip top bottom cover	
1	Keypad	

11.14.4 Safety and precautions

See *General precautions*, p.6.

11.14.5 Pre-removal checklist

Before proceeding with this disassembly, please make sure you have read and completed the following chapters:

- *Disassemble the Flip cover rubber and the Flip decorative part*, p.58
- *Disassemble the Flip top ASSY*, p.61

11.14.6 Procedure overview

The **PCBA ASSY** is removed by first removing the **Sealing silicone B hinge** and the **Screw4 flip top bottom cover**.

11.14.7 Step-by-step instructions

1. Use **Tweezers** to remove the **Sealing silicone B hinge**.



2. Remove the **Screw4** flip top bottom cover.



3. Carefully turn the **PCBA ASSY** around to not damage the **FPC**, the disconnect the **FPC**.



e

4. Remove the Keypad.



11.14.8 After-removal checks

- Make sure no cables or components are damaged during removal. Damaged cables and components must be replaced.

11.14.9 Troubleshooting tips

—

11.14.10 Related information

- *Assemble the Key PCB ASSY*, p.97

11.15 Disassemble the Hinge Flip bottom ASSY

11.15.1 Purpose

These steps describe how to disassemble the **Hinge Flip bottom ASSY**.

11.15.2 Tools and equipment

Type	Reference
Screwdriver	ISO 2380, ISO 8764, ISO 10664

11.15.3 Spare parts

11.15.4 Safety and precautions

See *General precautions*, p.6.

11.15.5 Pre-removal checklist

Before proceeding with this disassembly, please make sure you have read and completed the following chapters:

- *Disassemble the Battery cover ASSY*, p.30
- *Disassemble the ANT PCB*, p.49

11.15.6 Procedure overview

The **PCBA ASSY** is removed by first removing the **Sealing silicone B hinge** and the **Screw4 flip top bottom cover**.

11.15.7 Step-by-step instructions

1. Insert the **Screwdriver** into the hinge hole of the front shell assembly and push until you hear a click.



2. Slowly pull the **Front housing ASSY** and the **Hinge Flip bottom ASSY** apart.



3. Separate the **Front housing ASSY** and the **Hinge Flip bottom ASSY**.



4. Use the **Screwdriver** to push out the hinge.



5. Separate the **Hinge Flip bottom ASSY** and the hinge.



11.15.8 After-removal checks

- Make sure no cables or components are damaged during removal. Damaged cables and components must be replaced.

11.15.9 Troubleshooting tips

—

11.15.10 Related information

- *Assemble the Key PCB ASSY, p.97*

11.16 Disassemble the Hinge FPC

11.16.1 Purpose

These steps describe how to disassemble the **Hinge Flip bottom ASSY**.

11.16.2 Tools and equipment

No tools are required for this procedure. Tools used in earlier procedures are listed in their respective chapters.

11.16.3 Spare parts

11.16.4 Safety and precautions

See *General precautions*, p.6.

11.16.5 Pre-removal checklist

Before proceeding with this disassembly, please make sure you have read and completed the following chapters:

- *Disassemble the Battery cover ASSY*, p.30
- *Disassemble the ANT PCB*, p.49
- *Disassemble the Hinge Flip bottom ASSY*, p.68

11.16.6 Procedure overview

The **Front housing ASSY** disassembly is finalised by disconnecting the remaining **FPC's**.

11.16.7 Step-by-step instructions

1. Disconnect and remove the **Hinge FPC** from the **Front housing ASSY**.



2. Separate the the **Sealing silicone A hinge** from the **Hinge FPC**.



11.16.8 After-removal checks

- Make sure no cables or components are damaged during removal. Damaged cables and components must be replaced.

11.16.9 Troubleshooting tips

—

11.16.10 Related information

- *Assemble the Hinge FPC*, p.90

12. Assembly

12.1 Assemble the Front housing ASSY

12.1.1 Purpose

Describes how to correctly reinstall the parts on the **Front housing ASSY** after internal repairs or inspections.

12.1.2 Tools and equipment

No tools are required for this procedure. Tools used in earlier procedures are listed in their respective chapters.

12.1.3 Spare parts

Qty	Spare part	Information
1	Front housing ASSY	
1	Receiver	
1	Power key FPC	
1	Motor	
1	Speaker	
1	Antenna board FPC	
1	Volume key FPC	

12.1.4 Safety and precautions

See *General precautions*, p.6.

12.1.5 Preassembly checklist

- Check that the **Front housing ASSY** is free from dust or debris.

12.1.6 Procedure overview

This procedure outlines the sequential steps to reassemble the **Front housing ASSY**. Each part must be correctly aligned to ensure full functionality and avoid damage during reassembly.

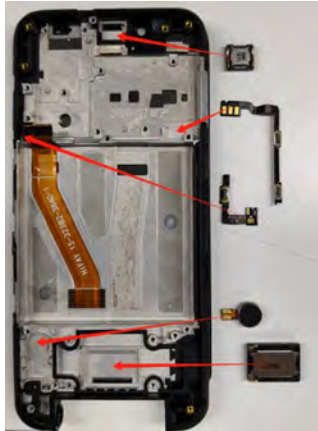

12.1.7 Step-by-step instructions

1. Assemble the **Receiver** on the **Front housing ASSY**.

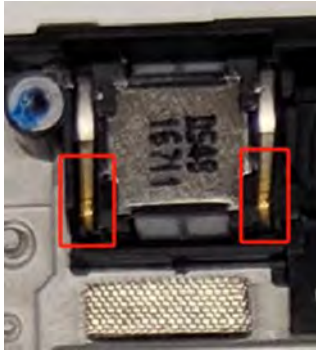

Note!

Make sure to position the **Receiver** according to the image.

2. Assemble the **Power key FPC** on the **Front housing ASSY**.
3. Assemble the **Volume key FPC** on the **Front housing ASSY**.

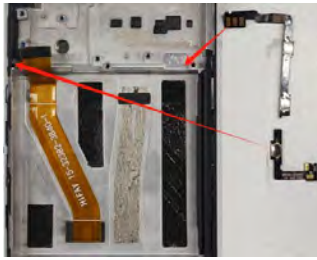
**Note!**

Both the **Power key FPC** and the **Volume key FPC** should be aligned with the notches and holes of the **Front housing ASSY** compartment.

4. Assemble the **Motor** on the **Front housing ASSY**.



5. Assemble the **Speaker** on the **Front housing ASSY**.

**12.1.8 Post-assembly checks**

- All components are secure fixed in place.
- Check that there are now loose cables or connectors.

12.1.9 Troubleshooting and tips

—

12.1.10 Related information

- *Disassemble the Front housing ASSY, p.54*

12.2 Assemble the USB Light sensor FPC

12.2.1 Purpose

Description of how to correctly reassemble the **USB Light sensor FPC**. This is done after disassembling or changing any of the parts.

12.2.2 Tools and equipment

No tools are required for this procedure. Tools used in earlier procedures are listed in their respective chapters.

12.2.3 Spare parts

Qty	Spare part	Information
1	USB Light sensor FPC	
1	Sensor rubber sleeve	

12.2.4 Safety and precautions

See *General precautions*, p.6.

12.2.5 Preassemble checklist

- Make sure that the components are free from dust and debris.

12.2.6 Procedure overview

Start by installing the **Sensor rubber sleeve** and then connect the **USB Light sensor FPC**.

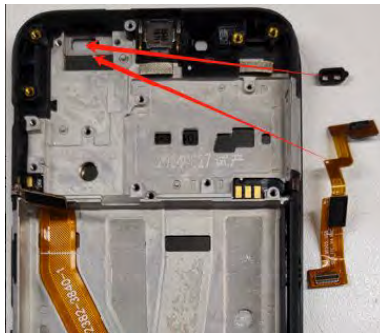

12.2.7 Step-by-step instructions

1. Assemble the **Sensor rubber sleeve** in the **Front housing ASSY**.



2. Connect the **USB Light sensor FPC**.



12.2.8 Post-assembly checks

- All components are secure fixed in place.
- Check that there are no loose cables or connectors

12.2.9 Troubleshooting and tips

—

12.2.10 Related information

- *Disassemble the USB Light sensor FPC*, p.45

12.3 Assemble the USB PCB

12.3.1 Purpose

Description of how to correctly reassemble the **USB PCB**. This is usually done after disassembling or changing any of the parts.

12.3.2 Tools and equipment

Type	Reference
Screwdriver	

12.3.3 Spare parts

Qty	Spare part	Information
1	USB PCB	
1	USB Light sensor FPC	
1	Screw1 SIM sub board	
1	Screw2 bracket	

12.3.4 Safety and precautions

See *General precautions*, p.6.

12.3.5 Preassemble checklist

—

12.3.6 Procedure overview

This procedure covers the installation of the **USB PCB**, securing it with screws, and connecting the **USB Light sensor FPC**, leaving it loose until later installation.

12.3.7 Step-by-step instructions

1. Position the **USB PCB** and push it into its slot, so that the screw holes on the **USB PCB** are levelled with the screw holes on the **Front housing ASSY**. Then, fasten it with the **Screw1 SIM sub board** (marked yellow), and the **Screw2 bracket** (marked red).



2. Connect the **USB Light sensor FPC** in the **USB PCB** on one end, and let the other hand be loose (until the **PCBA ASSY** is installed at a later stage).



12.3.8 Post-assembly checks

- Make sure that the **USB PCB** is aligned and levelled with the pins on the **Front housing ASSY**.

12.3.9 Troubleshooting and tips

—

12.3.10 Related information

- *Disassemble the USB PCB*, p.42

12.4 Assemble the SIM PCB

12.4.1 Purpose

The purpose of this section is to provide detailed instructions for reassembling the **SIM PCB**, making sure that all connections are properly aligned and secured to maintain device functionality.

12.4.2 Tools and equipment

Type	Reference
Screwdriver	ISO 2380, ISO 8764, ISO 10664

12.4.3 Spare parts

Qty	Spare part	Information
1	SIM PCB	
1	Screw1 SIM sub board	
1	Steel buckle	
1	SIM card FPC connection	

12.4.4 Safety and precautions

See *General precautions*, p.6.

12.4.5 Preassemble checklist

—

12.4.6 Procedure overview

The **SIM PCB** is reassembled by aligning, positioning, and securing components in the specified order. The reassembly sequence makes sure that all connections are securely fastened and properly aligned to prevent malfunction.



12.4.7 Step-by-step instructions

1. Connect the **SIM card FPC connection** to the **SIM PCB**.

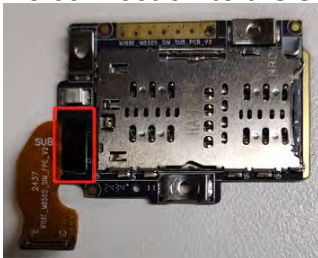

2. Position the **SIM PCB** and align its screw holes with the screw holes on the .



3. Position the **Steel buckle** on the **SIM card FPC connection** and align its screw holes to the **SIM PCB** and the and fasten them with the **Screw1 SIM sub board**.

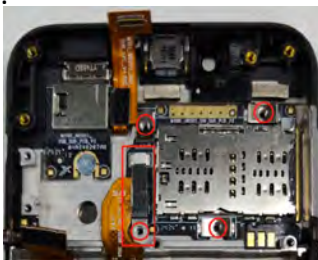

12.4.8 Post-assembly checks

—

12.4.9 Troubleshooting and tips

—

12.4.10 Related information

- *Disassemble the SIM PCB*, p.40

12.5 Assemble the PCBA ASSY

12.5.1 Purpose

Description of how to correctly reassemble the **PCBA ASSY**.

12.5.2 Tools and equipment

Type	Reference
Screwdriver	

12.5.3 Spare parts

Qty	Spare part	Information
1	PCBA ASSY	
1	Front camera 5M	
1	Rear main camera 13M	
2	Screw3 PCBA	
1	Rubber sleeve front camera	

12.5.4 Safety and precautions

See *General precautions*, p.6.

12.5.5 Preassemble checklist

—

12.5.6 Procedure overview

This procedure describes how to first assemble the front camera and position it on the . Next, the **PCBA ASSY** is prepared by attaching the rear camera. Finally, the **PCBA ASSY** is installed onto the .

12.5.7 Step-by-step instructions

1. Attach the **Rubber sleeve front camera** to the **Front camera 5M**.

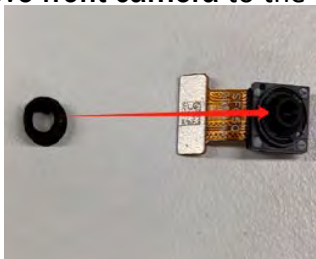

2. Assemble the **Front camera 5M** with the **Rubber sleeve front camera** in the .

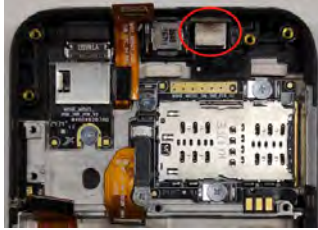

3. Position the **Rear main camera 13M** in the designated area of the **PCBA ASSY** and connect it according to the image.

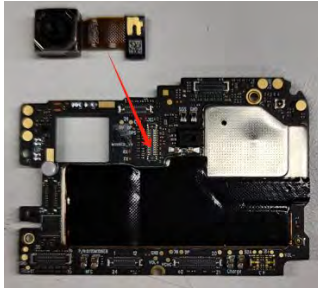

4. Position the **PCBA ASSY** in the and make sure to align it with the screw holes. Fasten the **PCBA ASSY** with the **Screw3 PCBA**.



5. Connect the **FP connectors**.

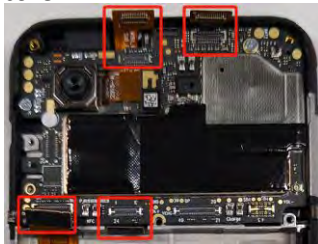

12.5.8 Post-assembly checks

- Make sure that the **FCP connectors** all are correctly connected to the **PCBA ASSY**.

12.5.9 Troubleshooting and tips

—

12.5.10 Related information

- *Disassemble the PCBA ASSY*, p.37

12.6 Assemble the ANT PCB

12.6.1 Purpose

Description of how to correctly reassemble the **ANT PCB**. This is done after disassembling or changing any of the parts.

12.6.2 Tools and equipment

Type	Reference
Prying lever	
Glue	

12.6.3 Spare parts

Qty	Spare part	Information
1	ANT PCB	
3		
1	Screw3 PCBA	

12.6.4 Safety and precautions

See *General precautions*, p.6.

12.6.5 Preassemble checklist

—

12.6.6 Procedure overview

This procedure outlines the steps to assemble the **ANT PCB** and secure it in the .



12.6.7 Step-by-step instructions

1. Position the **ANT PCB** in the **Front housing ASSY** and align the screw holes. Then, fasten the **ANT PCB** with the **Screw3 PCBA**.



2. Connect the **Antenna board FPC** to the connectors (marked with red circles) on the **Front housing ASSY**.



3. Position the **RF cable** cable in the **Front housing ASSY** and connect it to the ports on the **ANT PCB** and the PCBA according to the image.



12.6.8 Post-assembly checks

—

12.6.9 Troubleshooting and tips

—

12.6.10 Related information

- *Disassemble the ANT PCB, p.49*

12.7 Assemble the Hinge FPC

12.7.1 Purpose

Description of how to correctly reassemble the **Hinge FPC**.

12.7.2 Tools and equipment

Type	Reference
Prying lever	

12.7.3 Spare parts

Qty	Spare part	Information
1	Hinge FPC	
1	Sealing silicone A hinge	
1	Sealing silicone B hinge	

12.7.4 Safety and precautions

See *General precautions*, p.6.

12.7.5 Preassemble checklist

—

12.7.6 Procedure overview

This procedure outlines the steps to assemble the **Hinge FPC** and secure it in the .

12.7.7 Step-by-step instructions

1. Position the **Sealing silicone A hinge** on the **Hinge FPC**.





2. Thread the **Hinge FPC** through the dedicated hole in the .

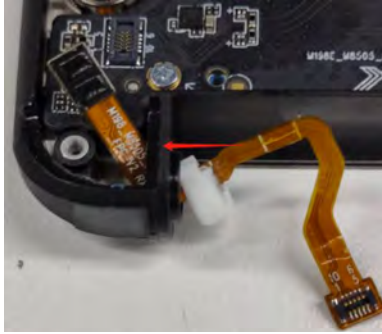

3. Fixate the **Hinge FPC** by fitting the **Sealing silicone A hinge** in the hole on the .



4. Assemble the **Sealing silicone B hinge** in the other hole on the .



12.7.8 Post-assembly checks

—

12.7.9 Troubleshooting and tips

—

12.7.10 Related information

- *Disassemble the Hinge FPC, p.72*

12.8 Assemble the Hinge Flip bottom ASSY

12.8.1 Purpose

Description of how to correctly reassemble the **Hinge** and **Hinge Flip bottom ASSY**.

12.8.2 Tools and equipment

Type	Reference
Prying lever	

12.8.3 Spare parts

Qty	Spare part	Information
1	Hinge	
1	Hinge Flip bottom ASSY	

12.8.4 Safety and precautions

See *General precautions*, p.6.

12.8.5 Preassemble checklist

—

12.8.6 Procedure overview

This procedure outlines the steps to assemble the **Hinge** into the **Hinge Flip bottom ASSY**. The **Hinge Flip bottom ASSY** is then assembled to the **Front housing ASSY**.

12.8.7 Step-by-step instructions

1. Insert the **Hinge** in the **Hinge Flip bottom ASSY**.



2. Push the **Hinge** into the hole.



3. The metal shell on the **Hinge** must be fully inserted into the hole of the **Hinge Flip bottom ASSY** according to the image.



4. Insert the pin of the **Hinge** into the dedicated spot on the **Front housing ASSY**.



5. To insert the **Hinge** pin on the other side of the **Front housing ASSY** and firmly push the **Hinge Flip bottom ASSY** in place using a **Prying lever** or **Tweezers**.



6. The **Front housing ASSY** and the **Hinge Flip bottom ASSY** should be perfectly aligned according to the image.

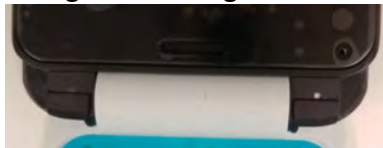

12.8.8 Post-assembly checks

—

12.8.9 Troubleshooting and tips

—

12.8.10 Related information

- *Disassemble the Hinge Flip bottom ASSY, p.68*

12.9 Assemble the Key PCB ASSY

12.9.1 Purpose

Description of how to correctly reassemble the **Key PCB ASSY**.

12.9.2 Tools and equipment

No tools are required for this procedure. Tools used in earlier procedures are listed in their respective chapters.

12.9.3 Spare parts

Qty	Spare part	Information
1	Key PCB ASSY	
1	Sealing silicone B hinge	
7	Screw4 flip top bottom cover	
1	Keypad	

12.9.4 Safety and precautions

See *General precautions*, p.6.

12.9.5 Preassemble checklist

—

12.9.6 Procedure overview

This procedure outlines the steps to position the and connect it to the .

12.9.7 Step-by-step instructions

1. Position the **Keypad** in the battery compartment of the device.

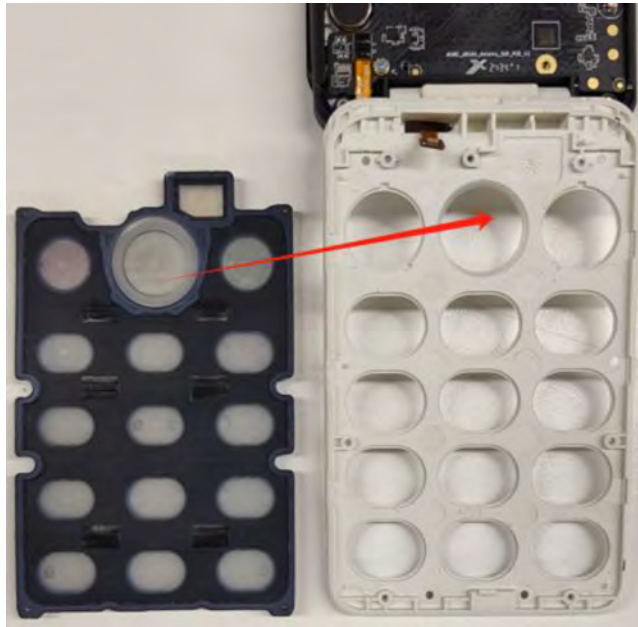

2. Connect the FPC to the Key PCB ASSY.





3. Assemble the **Sealing silicone B hinge** over. to the designated connector (marked red) on the **PCBA ASSY**.





4. Fasten the **Key PCB ASSY** with the **Screw4 flip top bottom cover**.



12.9.8 Post-assembly checks

—

12.9.9 Troubleshooting and tips

—

12.9.10 Related information

- *Disassemble the Key PCB ASSY*, p.64

12.10 Assemble the Flip top ASSY

12.10.1 Purpose

Description of how to correctly reassemble the **Flip top ASSY**.

12.10.2 Tools and equipment

No tools are required for this procedure. Tools used in earlier procedures are listed in their respective chapters.

12.10.3 Spare parts

Qty	Spare part	Information
1	Flip top ASSY	
7	Screw4 flip top bottom cover	

12.10.4 Safety and precautions

See *General precautions*, p.6.

12.10.5 Preassemble checklist

- Make sure that the device is free from dust and debris.

12.10.6 Procedure overview

This procedure outlines the steps to position the **Flip top ASSY**.

12.10.7 Step-by-step instructions

1. Position the **Flip top ASSY** on the device.



2. Turn the device over.



3. Fasten the **Flip top ASSY** with the **Screw4 flip top bottom cover**.



12.10.8 Post-assembly checks

—

12.10.9 Troubleshooting and tips

—

12.10.10 Related information

- *Disassemble the Flip top ASSY, p.61*

12.11 Assemble the Flip cover rubber and the Flip decorative part

12.11.1 Purpose

Description of how to correctly reassemble the **Flip cover rubber** and the **Flip decorative part**.

12.11.2 Tools and equipment

Not applicable.

12.11.3 Spare parts

Qty	Spare part	Information
1	Flip cover rubber	
7	Flip decorative part	

12.11.4 Safety and precautions

See *General precautions*, p.6.

12.11.5 Preassemble checklist

—

12.11.6 Procedure overview

Position the **Flip decorative part** to the device and fasten it with the **Flip cover rubber**.

12.11.7 Step-by-step instructions

1. Assemble the **Flip decorative part** to the .

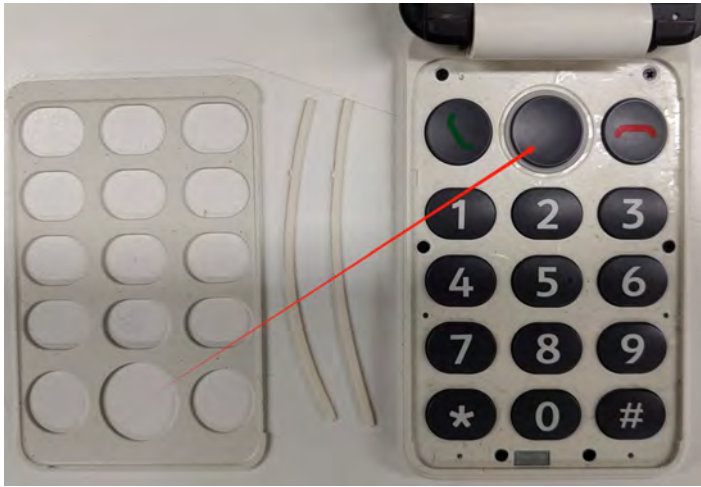

2. Insert the **Flip cover rubber** in the designated groove of the **Flip decorative part**.



3. Make sure the **Flip cover rubber** is flush to the **Flip decorative part**.



12.11.8 Post-assembly checks

—

12.11.9 Troubleshooting and tips

—

12.11.10 Related information

- *Disassemble the Flip cover rubber and the Flip decorative part, p.58*

12.12 Assemble the Battery

12.12.1 Purpose

Description of how to correctly reassemble the **Battery**.

12.12.2 Tools and equipment

No tools are required for this procedure. Tools used in earlier procedures are listed in their respective chapters.

12.12.3 Spare parts

Qty	Spare part	Information
1	Battery	
1	Battery adhesive A	
1	Battery adhesive B	
1	Battery adhesive C	

12.12.4 Safety and precautions

See *General precautions*, p.6.

12.12.5 Preassemble checklist

- Make sure that the adhesive tape is correctly positioned in the **Rear housing ASSY**.
- Check that the components are not damaged. Any damaged components should be replaced.
- Check that the battery is not punctured, crushed, or bent. A damaged battery can leak, catch fire, or even explode.

12.12.6 Procedure overview

Position the **Battery** in the battery compartment and then connect the **Battery FPC**.

12.12.7 Step-by-step instructions

1. Position the **Battery** in the battery compartment.



2. Connect the **Battery FPC**.



12.12.8 Post-assembly checks

- Check that the **Battery** sticks to the **adhesive tape**.

12.12.9 Troubleshooting and tips

—

12.12.10 Related information

- *Disassemble the Battery*, p.51

12.13 Assemble the Rear housing ASSY

12.13.1 Purpose

Description of how to correctly reassemble the **Rear housing ASSY**.

12.13.2 Tools and equipment

Type	Reference
Screwdriver	

12.13.3 Spare parts

Qty	Spare part	Information
1	Rear housing ASSY	
7	Screw2 bracket	

12.13.4 Safety and precautions

See *General precautions*, p.6.

12.13.5 Preassemble checklist

—

12.13.6 Procedure overview

The reassembly process is pushing the **Rear housing ASSY** into the correct position until it snaps into place.

12.13.7 Step-by-step instructions

1. Position the **Rear housing ASSY** on the device and align the screw holes on both parts.



Note!

Push the **Rear housing ASSY** into the correct position until it snaps into place.

2. Fasten the **Rear housing ASSY** with the **Screw2** bracket



12.13.8 Post-assembly checks

—

12.13.9 Troubleshooting and tips

—

12.13.10 Related information

- *Disassemble the Rear housing ASSY*, p.34

12.14 Assemble the Speaker bracket ASSY

12.14.1 Purpose

Description of how to correctly reassemble the **Speaker bracket ASSY**. This is usually done after disassembling or changing any of the parts.

12.14.2 Tools and equipment

Type	Reference
Screwdriver	

12.14.3 Spare parts

Qty	Spare part	Information
1	Speaker bracket ASSY	
9	Screw2 bracket	

12.14.4 Safety and precautions

See *General precautions*, p.6.

12.14.5 Preassemble checklist

—

12.14.6 Procedure overview

This section describes how to assemble the **Speaker bracket ASSY** by positioning it in place and fastening it with the **Screw2 bracket**.

12.14.7 Step-by-step instructions

1. Position the **Speaker bracket ASSY** on the **Rear housing ASSY** and make sure to align the screw holes.



2. Fasten the **Speaker bracket ASSY** with the **Screw2 bracket**.



12.14.8 Post-assembly checks

—

12.14.9 Troubleshooting and tips

—

12.14.10 Related information

- *Disassemble the Speaker bracket ASSY, p.47*

12.15 Assemble the Battery cover ASSY

12.15.1 Purpose

Assembling the **Battery cover ASSY** restores the back of the phone. This step makes sure the device is properly sealed and protected.

12.15.2 Tools and equipment

No tools are required for this procedure. Tools used in earlier procedures are listed in their respective chapters.

12.15.3 Spare parts

Qty	Spare part	Information
1	Battery cover ASSY	
1	Sealing foam battery cover	
1	Sealing foam adhesive	

12.15.4 Safety and precautions

See *General precautions*, p.6.

12.15.5 Preassemble checklist

- Inspect the **Sealing foam battery cover** (marked in the red box) and the **Sealing foam adhesive** (marked in the green box).
If either is damaged, clean the affected area and replace the material as needed.

**Note!**

The **Sealing foam adhesive** at the top of the **Battery cover ASSY** is particularly easy to damage if the **Plectrum** is inserted too far during disassembly. Inspect this area closely and make sure no tearing or deformation has occurred.

12.15.6 Procedure overview

This procedure outlines the steps to align and secure the **Battery cover ASSY** onto the device.

12.15.7 Step-by-step instructions

1. Align the **Battery cover ASSY** with the device. Start by positioning and securing the bottom edge by pushing in place.



2. Press the rest of the **Battery cover ASSY** into place.



12.15.8 Post-assembly checks

- Confirm that the **Battery cover ASSY** is fully seated and flush with the device frame, with no visible gaps along the edges.
- Press any external buttons (e.g., power button, volume keys) to verify they move freely and are not obstructed by the cover.
- Verify that openings for ports (USB, audio jack, SIM tray, etc.) are correctly aligned and not blocked by the back cover.

12.15.9 Troubleshooting and tips

- Misaligned clips causes the **Battery cover ASSY** to not snap in fully. Remove it and try again.

12.15.10 Related information

- *Disassemble the Battery cover ASSY, p.30*

12.16 Assemble the SIM card tray

12.16.1 Purpose

This is typically the final step in completing the full assembly of the smartphone.

12.16.2 Tools and equipment

—

12.16.3 Spare parts

Qty	Spare part	Information
1	SIM card tray	

12.16.4 Safety and precautions

See *General precautions*, p.6.

12.16.5 Preassemble checklist

- Make sure that the **SIM card tray** is clean and free from dust and debris. If not, it needs to be replaced.

12.16.6 Procedure overview

This procedure outlines the steps to insert the **SIM card tray** and make sure it is properly aligned with the device surface.

12.16.7 Step-by-step instructions

1. Locate the groove of the **SIM card tray**.
2. Insert the **SIM card tray** and make sure that it is flush with the surface of the device.

12.16.8 Post-assembly checks

—

12.16.9 Troubleshooting and tips

Check functionality after fully assembled the device.

12.16.10 Related information

- *Disassemble the SIM card tray*, p.28

13. Troubleshooting



CAUTION

This section is for technicians and repair professionals only.

You can retrieve diagnostic information by running a failure analysis on the device. This process identifies faults and error codes that help determine the appropriate repair actions.

To run the failure analysis tool:

1. Open the **Dialer** (Phone app).
2. Enter ***##*#38#*##***.
3. Select **Item test** to test a specific function or component, then follow the on-screen instructions.

Press the back button to exit the tool.

13.1 Reset software

For the full manual with all functions and features, see *Appendix*, p.120.

13.2 Device boot options

1. Make sure your device is turned off.
2. Press and hold the **Power button** and the **Volume Up button**. Keep them both pressed until the **Select Boot Mode**-screen appears, which could take up to five seconds (it might take the phone up to one minute to enter the system recovery).
3. Use the **Volume Up button** to select **Recovery Mode**, then use the **Volume Down button** to confirm .
4. Use the **Volume Up** or **Volume Down button** to select **Wipe data/factory reset**, then use the **Power button** to confirm .
5. Use the **Volume Up** or **Volume Down button** to select **Factory data reset**. Again, confirm tapping the **Power button**.
Once the action is complete, all the way at the bottom left, in white small text, the message **Data wipe complete** will briefly appear. The **Recovery system menu** will appear once again.
6. Use the **Volume Up** or **Volume Down button** to select **Reboot system now**.
7. Press the **Power button** to confirm and wait for your device to restart.

14. Appendix

The Aurora A20/A21 user manual covers phone functions, settings, and instructions on how to update the software and firmware. The manual is available at: <https://www.doro.com/>

Additional related documentation is available online at: <https://www.doro.com/repair/>

English

Version 1.1

©2025 Doro AB. All rights reserved.

www.doro.com

REV 24040 – STR